

HOT SHOT

IRRIGATION

810-R

RECEIVER GUIDE

Pg.

2	HOT SHOT OVERVIEW
3	FUNCTION SWITCH SETTINGS
3	ENGINE STARTUP MODE
3	SUPERVISION FEATURE
3	FAILSAFE OPERATION
3	LOAD SHARING
4	RECEIVER INDICATOR LIGHTS
4	LAST TRANSMITTER STANDING MODE
4	UNIT # SWITCHES
5	RECEIVER HOOKUP TO ENGINE DRIVEN WELL
6	RECEIVER HOOKUP TO ELECTRIC WELL
7	RECEIVER HOOKUP TO ELECTRIC WELL DIAGRAM

Hot Shot Systems Inc. will no longer sell or warranty its products for the use in controlling or monitoring pollutants. However, the use of these controllers in non pollutant applications such as water tanks, water pumps, pivots, irrigation systems and any other monitoring or control applications that do not involve pollutants are suitable for these products.

Version : 161808

ATTENTION: All Hot Shot units have a designated GROUND Terminal. Hot Shot units must have there ground terminal connected to a proper ground or grounding system as per the NEC (*National Electrical Code*) and or your local and state electrical code guidelines.

ATTENTION: Depending upon the style of system that your are going to control with the Hot Shot Wireless Controller you may need to supply additional parts. Such as relays, step-down transformers, Murphy switches etc. These items are suggested in the wiring guides that follow in this manual.

	⚠ WARNING
	<p>ELECTRIC SHOCK HAZARD.</p> <p>This equipment is to be serviced by trained personnel only.</p>
TEST SYSTEM DAILY	

HOW IT WORKS

Think of the HOT SHOT system as a control wire going from the transmitter site to the receiver site. When the Hot Shot Transmitter’s SENSOR ON-OFF Input is connected to COM, a 10 second delay timer is started. After the delay timer has expired, the transmitter will send the (Relay ON) command to the receiver. This will close the relay contacts between N.O. and COM. When the SENSOR ON-OFF input at the transmitter is opened it will send the (Relay OFF) command to the receiver switching the relay back to N.C. connected to COM. Battery backup in the transmitter will still allow the HOT SHOT to work in case of power outage. Each system is coded with its own four digit code so it will not interfere with other systems in the same area. The following manual has been prepared to provide details for Transmitter installation and Receiver installation on electric and engine driven wells.

MOUNTING

Cabinets are a weatherproof UV protected NEMA 4X cabinet with mounting ears on top and bottom. The Hot Shot cabinet can be mounted on the side of a control panel, pole or any other surface as long as the antenna does not have metal running within 12” of the antenna whip. If longer range is needed, an external long range antenna can be used. Do not mount the HOT SHOT receiver to the well engine or cover because the strong vibrations can be harmful to the unit.

CODE SWITCH SETTINGS

All transmitters and receivers will be shipped from the factory with preprogrammed 4 digit system codes. This ensures that your neighbor will not duplicate the same system code as your units. Your transmitter and receiver system codes should already match, so you do not need to program any codes. If a new secure system code is needed for your installation please call 785-623-1500 to be issued a secure system code for your area that the system will be operating in.

If you ever need to replace a unit due to servicing, the field code can be programmed to match the existing or new add on units. FOLLOW THE EXAMPLE BELOW...

FOR CODE QUESTIONS? CALL 785-623-1500

EXAMPLE: CODE 6789

KEY

3	4	5	6
7	8	9	0

Use the # KEY to the left to make each digit of the code. It takes three of the switches to make one number of the code.

Use switches 1,2,3 for the first # in the code. Switches 4,5,6 for the second #. Switches 7,8,9 for the third #. Switches 10,11,12 for the fourth #.

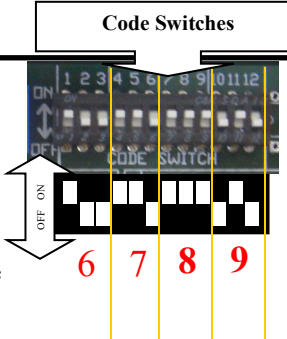

Code Switches

To watch a “How To” video on this feature click on the link below:

[“CODE SWITCH SETTINGS”](#)

RECEIVER UNIT 810-R

SWITCH#	FUNCTION SWITCH SETTINGS
1	ON WILL ACTIVATE MOMENTARY FOR 10 SEC.
2	ON INVERTED RELAY OUTPUT CONTROL
3	ON ACTIVATION OF RELAY DELAYED BY 10 SEC. (See Load Sharing below)
4	ON ACTIVATION OF RELAY DELAYED BY 5 SEC. (See Load Sharing below)
5	ON ACTIVATES THE OFF DELAY (50sec delay on the off command)
6	ON ACTIVATES ENIGNE STARTUP MODE - WITH 15MIN BY-PASS TIMER (See below)
7	ON ACTIVATES FAIL-SAFE MODE - SCENERIO 1 (See FAIL-SAFE OPERTAION below)
8	ON ACTIVATES THE SUPERVISION MODE - LED ONLY.
9	ON ACTIVATES FAIL-SAFE MODE - SCENERIO 2 (See FAIL-SAFE OPERTAION below)

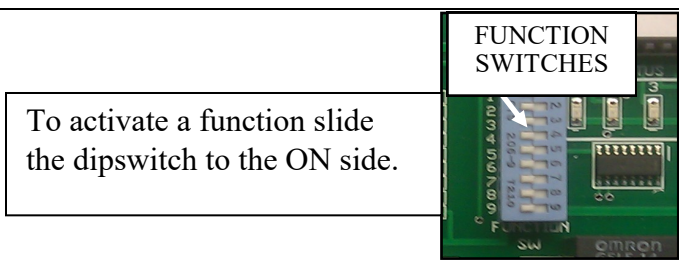

OFF DELAY

Turning function switch 5 ON will put the receiver in OFF DELAY mode. This mode is most often used with a Roto-Phase converter or generators. When the receiver gets the off command the deactivation of the relay will be delayed by 50 seconds allowing the Roto-Phase convertor or the generator the extra time needed to allow everything to shutdown.

ENGINE STARTUP MODE

Turn function switch 6 ON and then turn on the power to the receiver to enable the Engine Startup Mode. The Supervision LED will light up and the relay will come on to bypass the Murphy switch and allow the engine to start and stay running until the transmitter has sent its relay ON command to the receiver thus ending the bypass timer and taking control and turning off the Supervision LED. If the transmitter does not send the relay ON command within 15 min the receiver will kill the engine and you will have to turn the receiver off and then back on again to get it into Engine Startup Mode again.

To watch a "How To" video on this feature click on the link below:

["ENGINE STARTUP MODE"](#)

SUPERVISION FEATURE

The Supervision Feature is a great way for checking at a glance the integrity of communications between the transmitter and receivers. The supervision feature is designed to work with only one transmitter per system as the supervision feature's timer can operate on multiple receivers at the same time. When function 9 (Refresh) is turned on in the transmitter, it will send out a check-in signal (technically it's a command telling each receiver on the system to reset it's supervision timer, i.e. system is working properly) every 45 minutes. If the check-in signal is not heard by the receiver before the internal supervision timer expires, due to transmitter or receiver issues, the receiver will then look at its function switches (7, 8 or 9) and take the selected course of supervision action. See below.

FAIL-SAFE OPERATION

This feature works with the Supervision feature as described above but lets us take safety a step further. Fail-Safe Operation allows the receiver to control it's relay by activating or deactivating itself if the transmitter is not working properly.

SCENARIO 1

Turning on Function switch 7 will make the receiver's relay energize if there is a system failure (closing N.O. to COM.).

SCENARIO 2

Turning on Function Switch 9 will make the receiver's relay de-energize if there is a system failure (closing N.C. to COM.).

LOAD SHARING

Different delay times on the receivers can help with large electrical current pulls in the same field on start up.

RECEIVER UNIT 810-R

INDICATOR LIGHTS

POWER	Signals that the Receiver has power and is ready to receive.
STROBE	Used for troubleshooting, this LED flashes once for each of the four correct digits of the code received. The LED will stay on steady for one second if an incorrect digit of the code is received. <i>Example: If the LED flashes two times and then goes on steady it is indicating that the third digit doesn't match. If the LED flashes one time and goes on steady it is indicating that the second digit doesn't match. If the LED comes on steady right away it is indicating that the first digit doesn't match.</i>
STATUS 1 2 3 4	When these LED's are on it indicates that its corresponding transmitter has activated the relay and the receiver is in Last Transmitter Standing Mode (<i>Unit# switch and (Aux 7)</i>) See description below.
SUPERVISION	When this LED is flashing it indicates that it has not received its correct code from the transmitter in the past 3hrs. Sliding function switch #8 to its OFF position will turn off this indicator light.

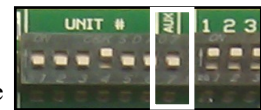
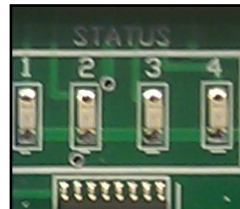

Last Transmitter Standing Mode (*Unit# switches and (Aux 7)*)

This mode is used when 2 or more (up to 4) different transmitters are sharing the same receiver and requiring the receiver's output relay stay latched until all the transmitters are done with the receiver and have transmitted the relay OFF command. Each STATUS LED on the receiver will light up when its transmitter has sent the relay ON command. When a transmitter sends its relay OFF command its corresponding LED on the receiver will turn off. For the receiver to include the transmitter in the control sequence the corresponding UNIT# switch on the receiver must be turned on for each transmitter that is controlling it. See UNIT# switches below.

NOTE - all transmitters must transmit the relay unlatch command or the receiver's relay will never unlatch possibly causing system damage.

To watch a "How To" video on this feature click on the link below:

["LAST PIVOT STANDING MODE"](#)

UNIT# SWITCHES(1,2,3,4,5,6,) AND (AUX #7)

When a Hot Shot Receiver (only 810-R) is going to be used with A Hot Shot 810-T transmitter using its #1,2,3,4,5 and 6 SENSOR control, the receiver's going to be used will need to be assigned to the sensor on the transmitter that will control it. All receivers come factory set in the default mode as a #1 receiver. Meaning they are only controlled by the SENSOR INPUT #1 of the transmitter. When using the SENSOR INPUT #2 or higher on the transmitter you will need to use the UNIT#

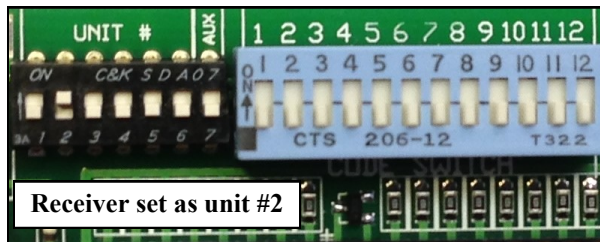

DIP SWITCHES located to the left of the 12-digit code bar on the receiver to program the receiver so it can be controlled by its designated sensor ON-OFF Input on the transmitter. You can make it a #2 receiver (*which is controlled by a #2 sensor transmitter*) by only turning on the #2 dipswitch. See picture. You can make it a #3 receiver (*which is controlled by the #3 sensor on the transmitter*) by only turning on the #3 dipswitch. This

makes it capable for the pivot to control and share multiple wells. Also see Multi Pivot Operation in the transmitter section.

TYPICAL HOT SHOT RECEIVER HOOKUP TO SHUTDOWN A ENGINE DRIVEN WELL

HOT SHOT RECEIVERS NEED TO BE TURNED ON BEFORE THE HOT SHOT TRANSMITTERS ARE TURNED ON. HOT SHOT TRANSMITTER ONLY TRANSMIT FOR 1 MINUTE. IF THE RECEIVER IS TURNED ON AFTER THE TRANSMITTER IT WILL NOT OPERATE CORRECTLY UNTIL THE TRANSMITTER IS SET TO TRANSMIT AGAIN.

AT THE ENGINE

DO NOT mount the HOT SHOT Receiver unit to the well engine or engine cover because strong vibrations can be harmful to the unit.

The diagrams below show a simple way to control an engine driven well using a simple 117 or 518 Murphy kill switch. Supply power to the receiver by hooking up the 12v positive input on the receiver to the 12v positive terminal on the battery. Run a wire from the Negative input on the receiver to the negative terminal on the battery or to a good ground connection. Install a jumper wire connecting the negative terminal to the COM terminal on the receiver. Connect a wire from the N.C. terminal on the Hot Shot receiver to the S or the SW1 terminal on the Murphy kill switch. Turn on function switch 6 and turn on the power to the receiver to enable the Engine Startup Mode (*for details see pg 3*). When activated the Supervision LED will come on and bypass the Murphy switch to allow the engine to start and stay running until the transmitter has sent its relay ON command to the receiver thus ending the bypass timer and taking control of the receiver and turning off the Supervision LED. If the transmitter has not sent the relay ON command within 15 min the receiver will kill the engine and you will have to turn the receiver off and then back on again to get it into Engine Startup Mode again. Now when the pivot is finished or the safety is tripped the receiver will be sent a stop water signal, the receiver's relay will close COM to NC. This shorts the S terminal to ground and kills the engine. Other variations and Murphy Kill switches will work as well.

Engine Driven Well Hookup Diagrams

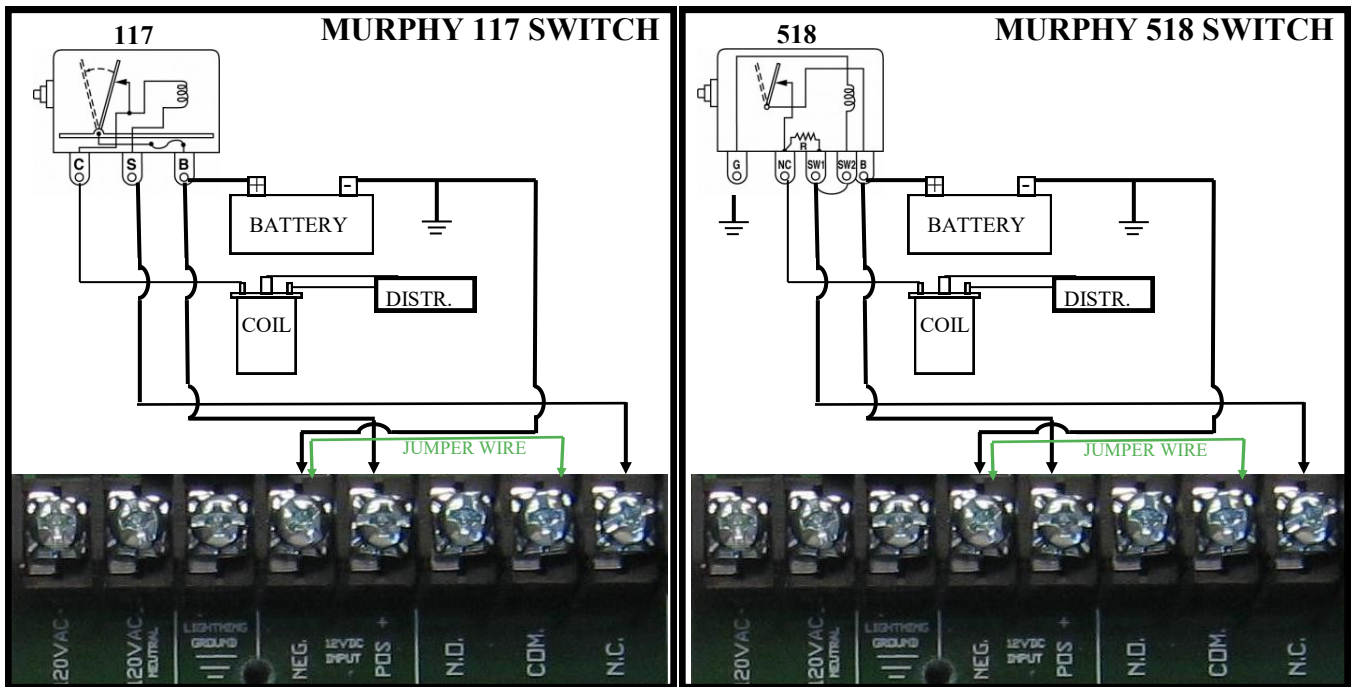

RECEIVER UNIT 810-R

CAUTION: Never switch any voltage greater than 120v with the Hot Shot Receivers internal relays. This will ruin the relay and void all manufacturer warranties. Use an externally mounted 120v coil relay to switch all voltages greater than 120v. See diagram on next page.

HOT SHOT RECEIVERS NEED TO BE TURNED ON BEFORE THE HOT SHOT TRANSMITTERS ARE TURNED ON. HOT SHOT TRANSMITTERS ONLY TRANSMIT FOR 1 MINUTE. IF THE RECEIVER IS TURNED ON AFTER THE TRANSMITTER IT WILL NOT OPERATE CORRECTLY UNTIL THE TRANSMITTER IS SET TO TRANSMIT AGAIN.

ELECTRIC WELL HOOKUP

- Mount a 480v-120v step-down transformer to supply 120v to the receiver. The Hot Shot Receiver only requires 1 watt of power to operate. *Hot Shot Systems suggest using a minimum of a single phase 60 hertz 0.050kVA transformer. They are available for purchase through Hot Shot Systems, just request when ordering.*
- Mount a 3 terminal fuse block and a 120vac relay. *Hot Shot Systems suggest using a 115V AC coil relay. They are available for purchase through Hot Shot Systems, just request when ordering.*
- Wire two, 480v conductors through the first two fuses (1/2 or 1 amp each) to the primary side of the step-down transformer. **Terminals may be different according to the transformer installed.**
- Wire the 120v **X1** terminal of the step-down transformer through the remaining fuse (1 amp) which then goes to the first 120vac input of the Hot Shot Receiver (120 volt polarity does not matter).
- Wire the 120v **X2** terminal of the step-down transformer to the neutral 120vac input of the Hot Shot Receiver (see diagram on the next page).
- Add a jumper from the first 120vac terminal to the Hot Shot Receivers relay **COM.** terminal (see diagram on the next page).
- Wire the **NO.** terminal on the Hot Shot Receiver to one side of the 120v relay coil.
- Connect the other side of the relay coil to the **X2** terminal of the step-down transformer.
- Connect a wire from the **Ground** terminal of the Hot Shot Receiver to a central grounding system (*ground rod*).

RECEIVER UNIT 810-R

ELECTRIC WELL HOOKUP DIAGRAM

OBJECT: WHEN THE HOT SHOT TRANSMITTER'S ON-OFF INPUT TO COMMON IS CLOSED IT SENDS OUT THE RELAY ON COMMAND TO THE RECEIVER. WHEN THE HOT SHOT RECEIVER GETS THE ON SIGNAL IT WILL CLOSE ITS N.O. TO COM CONTACTS. THIS WILL ENERGIZE THE 120VAC RELAY TO CLOSE THE 480V CONTACTOR.

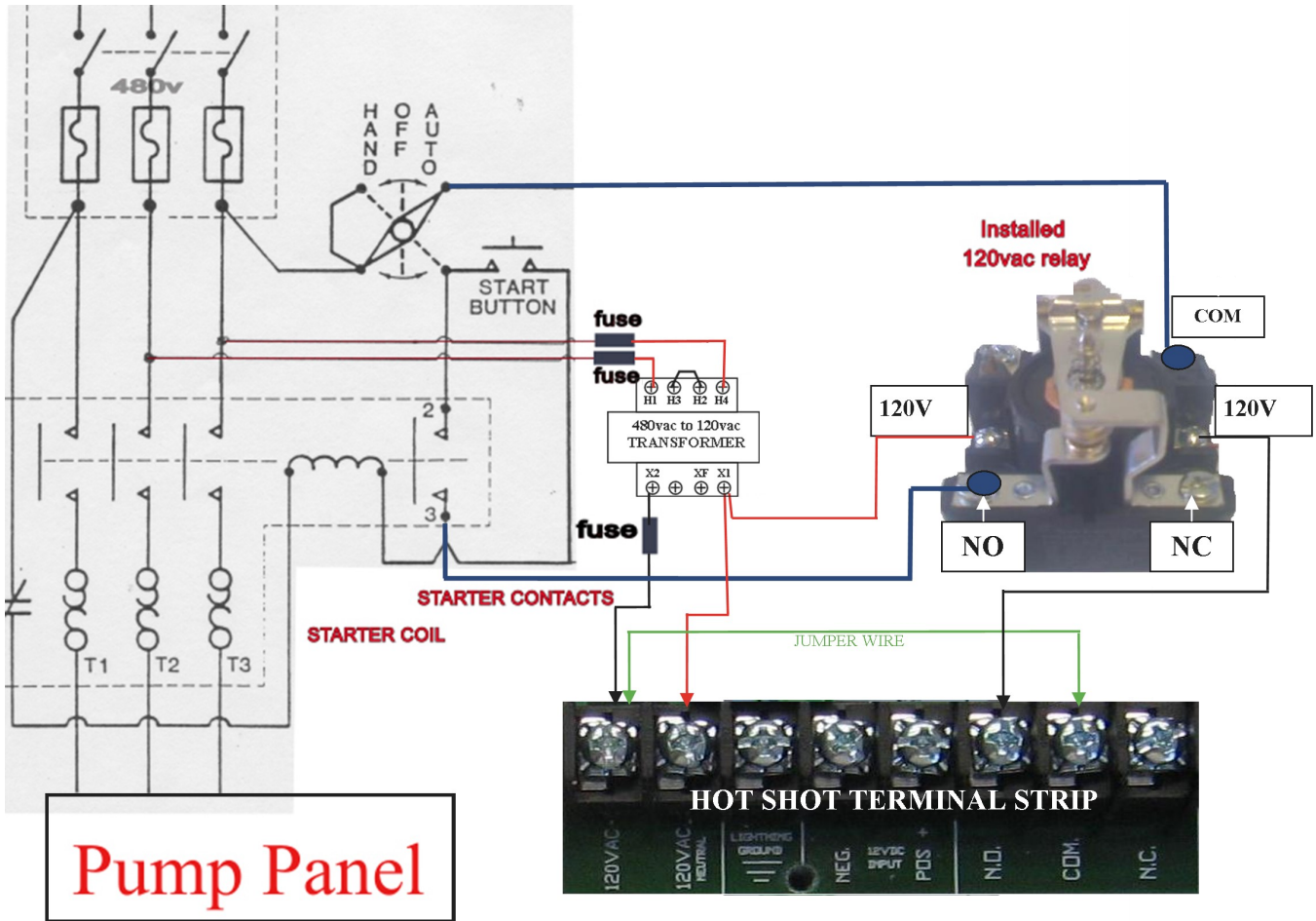

HOT SHOT GROUNDING FOR SAFETY AND PEAK PERFORMANCE

Hot Shot wireless systems are equipped with a GROUND terminal that needs to be connected to an NEC approved ground rod. A Hot Shot has various lightning and static protection devices incorporated on the circuit board that require proper grounding to operate. Any equipment or device panels operating with or near the Hot Shot should also be connected to the grounding system. A good ground will enhance the transmit and receive range of the Hot Shot System.

To watch a "How To" video on this feature click on the link below:

["PROPER GROUNDING"](#)

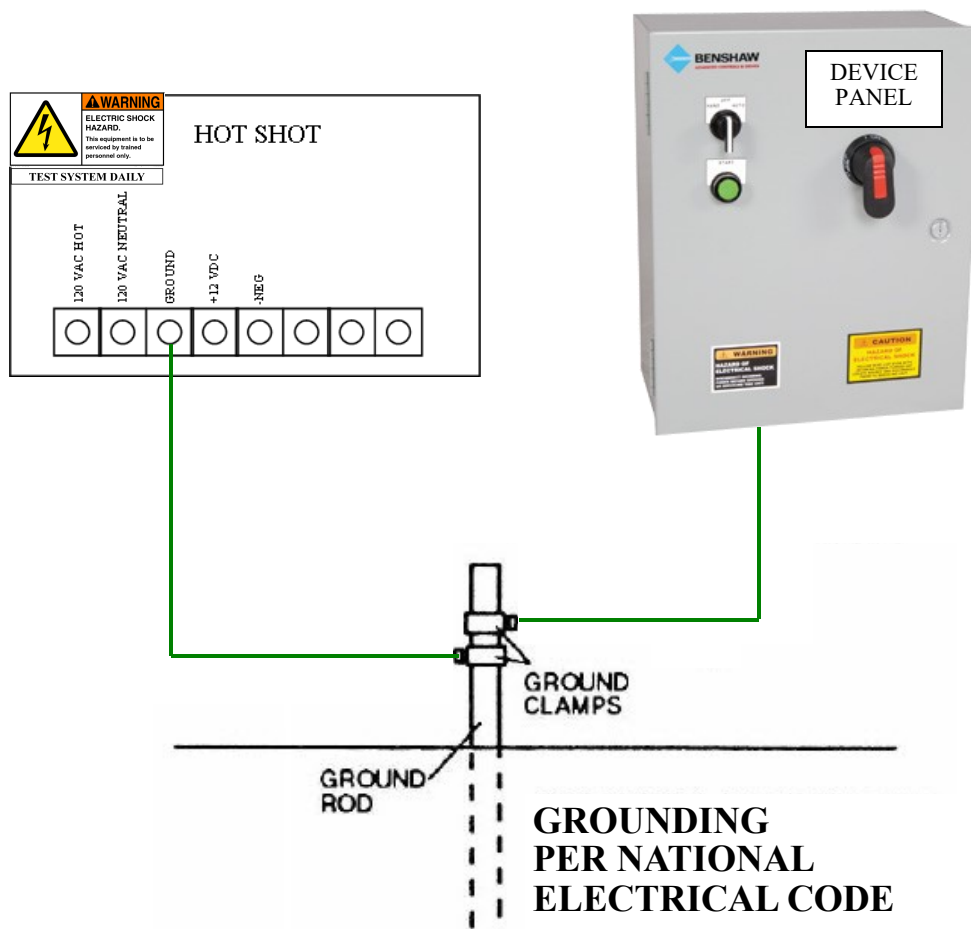

APPENDIX

SUPERVISION FEATURE

The Supervision Feature is a great way for checking at a glance the integrity of communications between the transmitter and receivers. The supervision feature is designed to work with only one transmitter per system as the supervision feature's timer can operate on multiple receivers at the same time. When function 9 (Refresh) is turned on in the transmitter, it will send out a check-in signal (*technically it's a command telling each receiver on the system to reset it's supervision timer, i.e. system is working properly*) every 45 minutes. If the check-in signal is not heard by the receiver before the internal supervision timer expires, due to transmitter or receiver issues, the receiver will then look at its function switches (7, 8 or 9) and take the selected course of supervision action. See below.

Receiver's Supervision/Fail Safe action:

If **Function 8** is on in the receiver and the supervision timer does not get reset by the transmitter's check-in signal the supervision LED will begin to blink continuously. No action will be performed by the receivers relay. The supervision LED will continue to blink until either the receiver receives the transmitter's check-in signal or the receiver is reset by pressing the reset button, if equipped, or by cycling the power to the receiver.

If **Function 7** (Fail Safe Scenario 1) is on in the receiver and the supervision timer does not get reset by the transmitter's check-in signal the supervision LED will begin to blink continuously. This will also activate the receivers relay which will close or open your contacts, (*N.C. / N.O.*) possibly triggering an alarm, call out system, deactivate an external relays coil or trip a tattletale circuit to stop the device it is controlling. The supervision LED will continue to blink and the receivers relay will stay activated until either the receiver receives the transmitter's check-in signal, a relay reset command from the transmitter or the receiver is reset by pressing the reset button, if equipped, or by cycling or losing power to the receiver.

Operational Note: When using Fail Safe Scenario 1, the receiver's relay is energized and if power is lost while the receiver is in Fail Safe operation, the receiver's relay will de-energize. When power is restored, the receivers relay will not immediately go back into Fail Safe operation. The receivers relay will remain de-energized and the device it is controlling may restart. The receiver will not go into Fail Safe operation again until it's supervision timer has expired again. If this situation occurs, a tattletale device that does not recycle when the power comes back on, should be installed to hold the circuit as needed for your situation.

If **Function 9** (Fail Safe Scenario 2) is on in the receiver and the supervision timer does not get reset by the transmitter's check-in signal the supervision LED will begin to blink continuously. This will also deactivate the receiver's relay, if currently activated, which will close or open your contacts, (*N.C. / N.O.*) possibly triggering an alarm, call out system, deactivate any external relays coil or trip a tattletale circuit to stop the device it is controlling. The supervision LED will continue to blink until either the receiver receives the transmitter's check-in signal or a relay ON or OFF command from the transmitter.

Transmitter Setting for Supervision/Fail Safe Operation at the Receiver:

Function 9 (*Refresh - sends checking in signal every 45 min.*)

This function must be turned on in the transmitter so the transmitter will send out the signal to make the receiver(s) supervision timer reset. IF the transmitter does not have this function turned on the absence of the refresh/check in signal will cause the receiver(s) to go into Supervision or a Fail Safe action.

Testing Supervision/Fail Safe Operation:

A good way to test the Supervision/ Fail Safe Operation is to turn off function switch 9 on the transmitter, so it will no longer send the refresh/check-in signal. Once the receiver's supervision timer has expired, (*may take up to 3 hrs depending on the version of software the receiver is operating*) the Supervision LED will begin to blink and depending upon the Fail Safe scenario you have chosen, the receivers relay will activate or de-active.

To watch a "How To" video on this feature click on the link below:

["SUPERVISION FEATURE"](#)

NO FCC LICENSE REQUIRED

FCC License is not required. This device operates on frequencies authorized for use in the Multi-Use Radio Service (MURS). MURS frequencies are available for unlicensed business or personal use. Any changes or modifications may void the user's authority granted by the FCC to operate this radio and should not be made. Use of this radio outside the country where it was intended to be distributed is subject to government regulations and may be prohibited.

NOTE: This equipment has been tested and found to comply with the limits for a Class B digital device, pursuant to part 15 of the FCC Rules. These limits are designed to provide reasonable protection against harmful interference in a residential installation. This equipment generates, uses and can radiate radio frequency energy and, if not installed and used in accordance with the instructions, may cause harmful interference to radio communications. However, there is no guarantee that interference will not occur in a particular installation. If this equipment does cause harmful interference to radio or television reception, which can be determined by turning the equipment off and on, the user is encouraged to try to correct the interference by one or more of the following measures:

- **Reorient or relocate the receiving antenna.**
- **Increase the separation between the equipment and receiver.**
- **Connect the equipment into an outlet on a circuit different from that to which the receiver is connected.**
- **Consult the dealer or an experienced radio/TV technician for help.**

15.21 INFORMATION to USER:

The users manual or instruction manual for an intentional or unintentional radiator shall caution the user that changes or modifications not expressly approved by the party responsible for compliance could void the user's authority to operate the equipment.

Warranty

The warranty below constitutes the only warranty in connection with any sale from Hot Shot Systems Inc. and is in lieu of all other warranties, express or implied, written or oral. THERE ARE NO IMPLIED WARRANTIES OF MERCHANT-ABILITY OR FITNESS FOR A PARTICULAR PURPOSE THAT APPLY TO ANY SALE FROM HOT SHOT SYSTEMS INC.

Hot Shot Systems Inc., warrants to You that Products (Products meaning any item purchased from Hot Shot Systems) will be free from defects in materials and workmanship under normal use and service for one (1) year from the purchase date. A product issue under this Limited Warranty must be presented during the Limited Warranty period and within thirty (30) days after any covered condition has occurred. A claim under this Limited Warranty shall be satisfied by either, in Hot Shot Systems sole discretion, repairing or replacing the Product. Replacement Products may be new or reconditioned.

To make a claim under this Limited Warranty, Hot Shot Systems must first issue You a Returned Material Authorization (RMA) number. This number can be obtained by calling Hot Shot Systems and a RMA number will be provided over the phone. A copy of the RMA number must be included with any materials shipped to Hot Shot Systems. The entirety of Products must be sent back to Hot Shot Systems and properly packaged to ensure against damage during shipping. If Hot Shot Systems determines that the claim is covered by this Limited Warranty, Hot Shot Systems will either, in its sole discretion, repair or replace the Products and/or part. Any damages not covered under this Limited Warranty will not be repaired until a purchase order is received.

The Limited Warranty period shall not be extended by the replacement or repair of Products or parts under this Limited Warranty but the remaining Limited Warranty period shall continue in effect and be applicable to the replaced or repaired Products or parts under conditions of the Limited Warranty.

The term "Long Range Wireless Control" is not a guarantee of proper radio operation everywhere in all conditions. Radio operation is subject to transmission and receive limitations, customer equipment, weather, topography and other environmental and electrical considerations associated with radio technology also affect radio operation and radio operation may vary significantly within buildings. The radio operation range of Products is not guaranteed, and Hot Shot Systems cannot and does not guarantee or represent that the radio operation will operate correctly in all conditions. It is Your responsibility to determine daily if radio operation is operating correctly and to monitor the Products to determine the communication between Products. You should contact Hot Shot Systems for assistance if needed. As such, Hot Shot Systems is not liable for any causes of action, pollution, incurred costs, losses of any kind or damages of any kind whatsoever arising out of mistakes, omissions, interruptions, errors, customer equipment or defects in the radio operation and or Products.

Intended Use. Products are intended for non pollutant, non hazardous and non critical use only. Products are to be used and installed per the installation guide and any other instructions provided by Hot Shot Systems (collectively, the "Seller's Guidelines"). Any use beyond the intended non pollutant, non-hazardous and non critical use or against the Seller's Guidelines ("Unintended use") are at the End-User's own risk, and Hot Shot Systems does not warrant or make any representations whatsoever regarding the use of Products for any unintended use. Hot Shot Systems' Products are convenience items and are not intended to be a substitute for normal maintenance, monitoring, control and proper upkeep of equipment or property that Products are monitoring or controlling. Hot Shot Systems' Products are convenience items and are not intended to monitor equipment, control equipment, liquids, chemicals or other items which are pollutants, vital, hazardous, necessary, and/or have life-or-death consequences. The End-User should take care to determine prior to use whether Products are suitable, adequate or safe for the use intended. Since individual applications are subject to great variation, Hot Shot Systems makes no representation or warranty as to suitability or fitness of Products for any specific application.

Upon expiration of the Limited Warranty period, all liability of Hot Shot Systems shall be terminated. This Limited Warranty will also be terminated immediate due to any of the following cases: failure to follow installation and operating instructions, misuse or "Unintended use", alteration, abuse, accident or tampering, and repair by anyone other than Hot Shot Systems.

THIS LIMITED WARRANTY IS EXCLUSIVE AND EXPRESSLY IN LIEU OF ALL OTHER WARRANTIES, OBLIGATIONS OR LIABILITIES, WHETHER WRITTEN, ORAL, EXPRESS OR IMPLIED, INCLUDING ANY WARRANTY OF MERCHANT-ABILITY OR FITNESS FOR A PARTICULAR PURPOSE, OR OTHERWISE. IN NO CASE SHALL HOT SHOT SYSTEMS BE LIABLE TO ANYONE FOR ANY CONSEQUENTIAL OR INCIDENTAL DAMAGES FOR BREACH OF THIS WARRANTY OR ANY OTHER WARRANTIES WHATSOEVER. This Limited Warranty gives specific legal rights.

No employee, agent, dealer or other person is authorized to give any warranties on behalf of Hot Shot Systems Inc., nor to assume for it any other liability in connection with any of its products, except an officer of Hot Shot Systems Inc., in a signed writing.

LIABILITY

Hot Shot Systems Inc. and its directors, officers, employees, subsidiaries and affiliates shall not be liable for pollution, pollution clean up, personal injury, property damage, hazardous conditions created, fluid spill cleanup, loss of product, loss of profit, or any other loss or expenses based on a claim the product(s) failed to operate properly. Test product daily to see if any malfunctions are present. If using this product in a situation where it is extremely critical to control your device to prevent damage of any kind, you must also use a call out system to notify a person in control of this situation. If this warranty and statement of liability is unacceptable, then do not purchase these products.

Hot Shot Systems makes no representation that Products and Services will reduce any risk of property loss, product loss, loss of profit, pollution or personal injury or prolong the life of any equipment or other property; or that Products and Services will in all cases provide adequate warning and protection. You understand that Products if properly installed and maintained may only reduce the risk of property loss or other loss but Products and Services are not an insurance or a guarantee that there will be no property loss, product loss, loss of profit, pollution or personal injury or other loss as a result. **CONSEQUENTLY, HOT SHOT SYSTEMS SHALL HAVE NO LIABILITY FOR ANY POLLUTION, PRODUCT LOSS, LOSS OF PROFIT, PROPERTY DAMAGE, PERSONAL INJURY OR OTHER LOSS OR EXPENSES INCURRED BASED ON A CLAIM THE PRODUCTS AND SERVICES FAILED TO GIVE WARNING.**

